

# Forklift Scales



## **VFS120 Forklift Scale**

---

Accuracy over Time

---

Rugged and Reliable

---

Designed for Safety

---

Low Cost of Ownership

---

**Robust, Accurate and Safe**  
Forklift Weighing

**METTLER TOLEDO**

# One-Step Weighing Saves Time and Money

**METTLER TOLEDO heavy-duty forklift scales make weighing a one-step operation. Designed for use in tough industrial environments, our scales set the standard for accuracy, safety and reliability.**

## Save Time



One-step weighing with a forklift eliminates the need to transport loads to and from a floor scale. Speed up the handling process by weighing onboard. Weight data is automatically transferred.

## Save Money



Forklift weighing is the quickest way to check the weight of pallets and ensure they are invoiced for correctly. Recover revenue that otherwise would have been lost.

## Manage Data



Software saves a complete transaction record, eliminating the error and inefficiency associated with manual data entry. Weight can be sent to a smart device and merged with dimensional and ID data.



### Maintain Accuracy

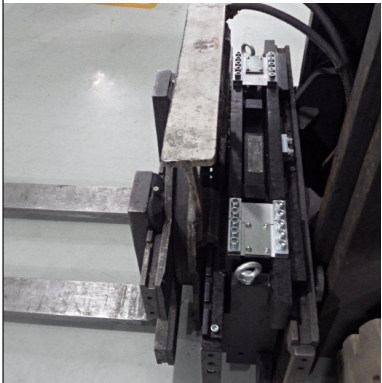

The unique three-point suspension holds calibration for up to twelve months with no need for recalibration. This reduces the expense and inconvenience associated with frequent readjustment.

### Operate Safely



The center of the weighing carriage is open, making it easy for the operator to see loads, position forks for lifting and stay out of the way of other forklift traffic.

### Ensure Uptime



The scales are constructed of solid steel and designed to withstand years of heavy use. Robust design and little required maintenance ensures uptime when other scales break down.

# Maintain Accuracy In All Conditions

In industrial environments, a number of factors can affect on-board weighing performance. The unique design of METTLER TOLEDO forklift scales maintains legal-for-trade accuracy in demanding conditions, where other scales struggle.

## Any Height

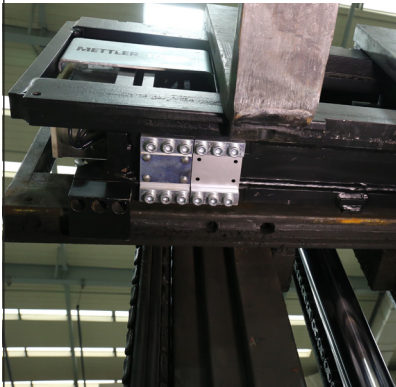

Sometimes fork height becomes uneven as a result of wear and tear. Angular compensation maintains accuracy regardless of the height of the two forks.

## Any Position



The corner adjustment function allows shipments to be accurately weighed, regardless of where goods are placed on the pallet.

## Any Environment

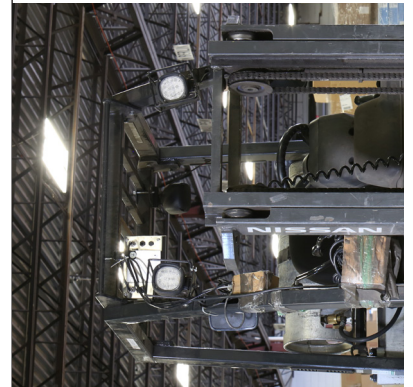

Advanced filter processing means that the scale can filter out vibrations and achieve the same accuracy on all forklifts, including diesel ones.



Adjustable locating tab keeps scale carriage aligned laterally.

Patented three-point suspension allows easy installation without shimming. Maintains calibration for more than 12 months.

Load cells and cables are positioned inside the scale frame for maximum protection.

Reliably transmit weight data via cable and junction box.

Patented split flexures increase weighing accuracy by stabilizing the load of the load cells more effectively

Largest viewing window in the industry offers maximum visibility and safety.

Under carriage safety hook provides safety without interfering with three-point suspension.

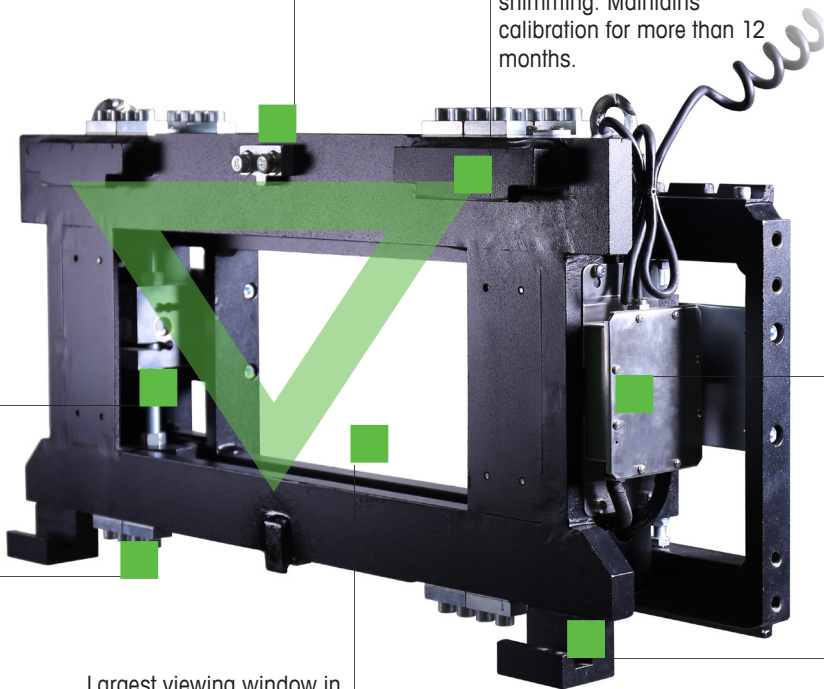

# Secure and Reliable For Safe Operation

**Safety is paramount in fast-paced freight-handling environments. The VFS120 was designed with operator safety as a priority. Features that ensure that operators are always in control help to avoid accidents and maintain productivity.**

## Safety Test Approved



All precautions have been taken to ensure safe operation of our scales. The VFS120 has undergone one million fatigue tests to prove its mechanical safety and durability.

## Exceptional Operator Visibility



A visibility window placed at the center of the weighing carriage allows the operator to position, load and transport goods safely while maintaining optimal productivity.

## System Protection



The robust design protects internal components from knocks, bumps and even crashes. If the forks tilt too far to safely weigh, the scale terminal alerts the operator to the problem.

# Low Cost of Ownership

## Little Maintenance Required

When investing in a forklift scale, it is important to consider not only the initial purchase price, but also performance, reliability and maintenance that will impact your business for years to come.

### Quick Return on Investment



Our entry-level forklift scale is designed to offer freight and LTL companies the functionality they need while keeping investment costs down. Payback is quick, from just a few days to around six months.

### Low Maintenance Costs

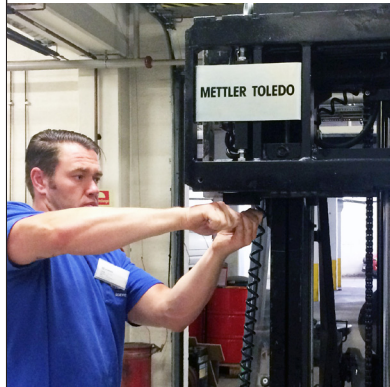

Many scales require frequent adjustment to maintain accuracy in heavy-use environments. Our forklift scales hold calibration for up to 12 months and require very little service or maintenance.

### Built to Last



Robust scales provide high-performance weighing over time. A solid steel front plate protects the load cells and electronics from damage that routinely puts other forklift scales out of commission.

# Superior Service

## Uptime When it Matters

**When equipment is directly linked to revenue and productivity, downtime is costly. Rely on METTLER TOLEDO Service to keep your operation running smoothly.**

A METTLER TOLEDO forklift scale saves you time and money. Consider how much you stand to lose if it is out of commission. Our highly trained installation and service team is here to make sure your scale is working around the clock.

### **Benefit From:**

- Expert Installation & Calibration
- Preventative Maintenance
- On-Site Training
- Tailored Service Packages



[www.mt.com/VFS120](http://www.mt.com/VFS120)

Visit for more information

**Mettler-Toledo AG**  
Industrial Division  
CH-8606 Nänikon, Switzerland

Local contact: [www.mt.com/contacts](http://www.mt.com/contacts)

Subject to technical changes  
© 09/2015 Mettler-Toledo AG  
MTSI 30233375